

ABSTRACT

Mr. Atulya Dhungana, a proud father of two, noticed that the family would buy multiple bikes per child as each grew out of one after another, Figure 1. Aside from being wasteful, Mr. Dhungana quickly realized it was expensive as well. This led to a question, "Why isn't there a bike which expands and grows as a child does?" The sponsor connected with Trine University and a design team was tasked with creating a bike targeting children ages three to nine, whose frame and components could expand and lengthen as needed to fit a child's growing frame. Through the sponsors concept drawings, extensive research into prior patents, concept generation, and implementation. The team decided to keep the back and front triangle fixed and only have an extendable front tube that will increase and decrease the

length of the bicycle. The team found this to be the most effective and safe way to produce a modular bike that will allow for easy adjustment while being secured via a clamp.



Figure 1: Typical Child Bike

CUSTOMER NEEDS/SPECS

The bike needed to be able to accommodate children from ages 3-9 and grow with the child these were the main requirements for the students. The team came up a list of what other needs or wants a consumer might have. The team then looked at the specifications like the wheel hubs should be able to accommodate all wheels from 12" to 24". Shown in Table 1 is the list of customer needs and specifications .

Table 1: Customer Needs

Customer Needs

- Weight
- Modularity
- Ease of Assembly
- Safety
- Price

Prototype

- The frame is made of 1025 steel with a wall thickness of 0.065". This allows for a heavier frame and lower center of gravity for younger riders.
- Ridable to Children 5-9 years of age and/or bike tires of 18"-25"
- No assembly required unless changing out tire size. Small adjustments, such as clamp adjustment will be needed.

DESIGN CONCEPTS

Originally each team member came up with an idea for the modularity of the bike. The students then reconvened with each other to discuss all of the ideas that were devised. Then after careful consideration, attributes from each team members ideas were taken and put together to get the first design. The ideas were for the front wheel hub to be modular, have the front bar be modular, keep a fixed back

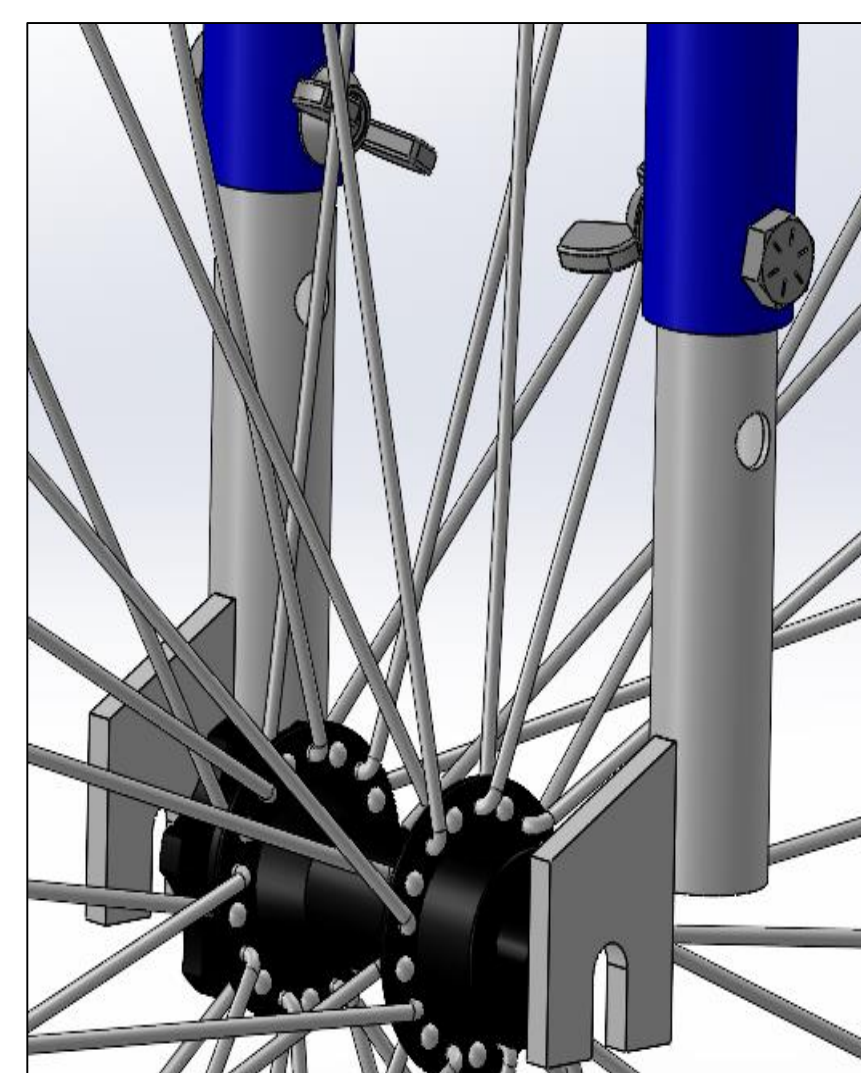

frame, and have the handlebars be modular as well. Figure 2 Identifies the front wheel hub design the team came up with to provide the needed adjustment. The handlebar design is seen in Figure 3.

Figure 2: Hub Modularity

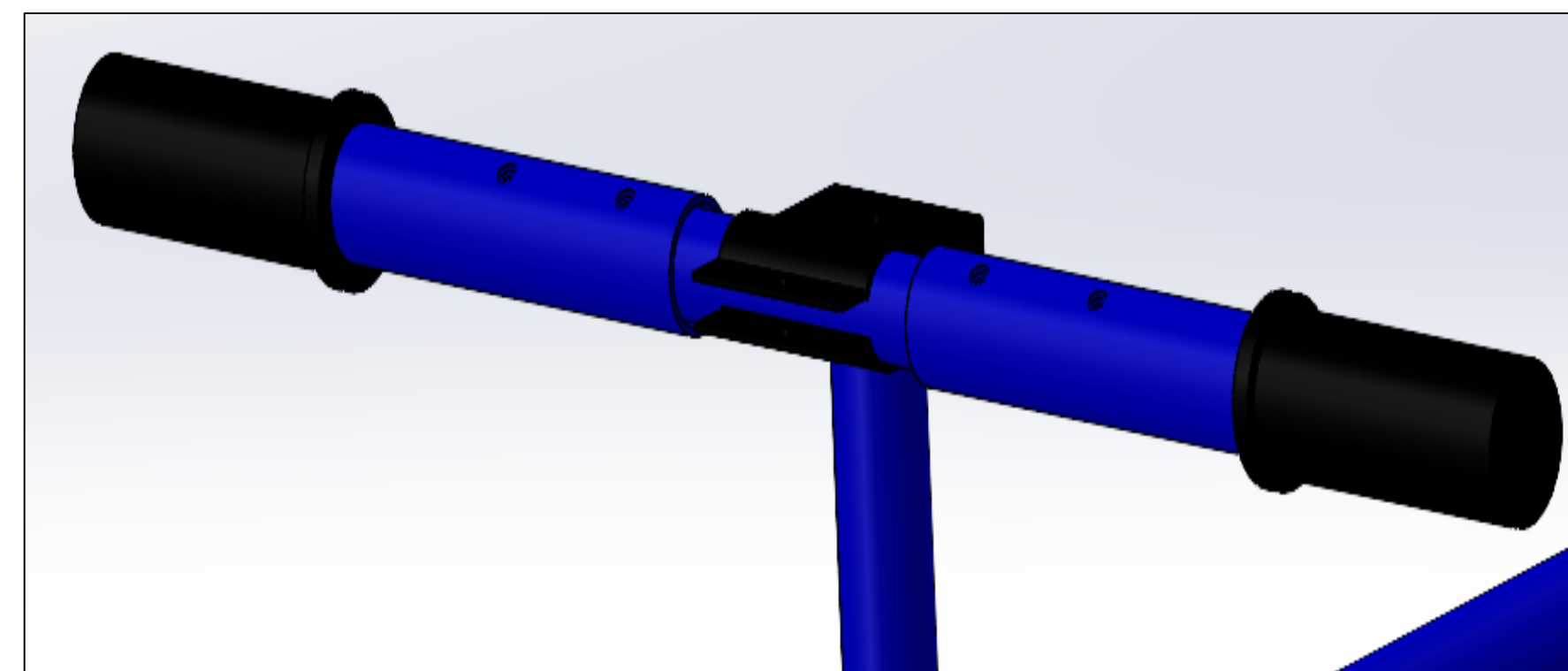

Figure 3: Modular Handlebars

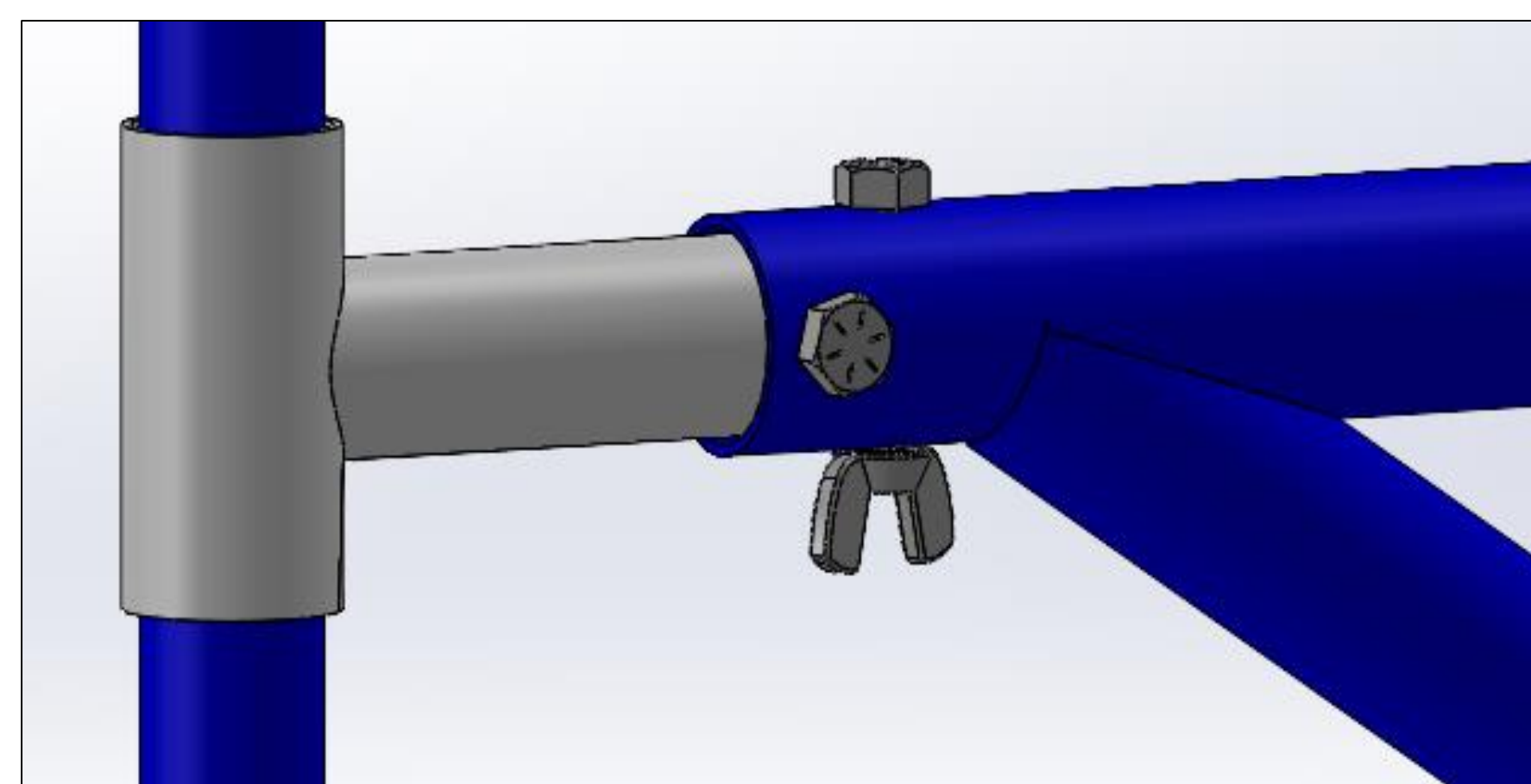

Figure 4: Horizontal Front Modularity

The team ended up choosing to make the frame components from 1026 steel, which will allow for the necessary added weight and subsequent lower center of gravity which can help young bike riders stay upright on the bicycle as they are learning the new skill. It was a design requirement for the tube holding the seat had to be angled backwards to allow for further riding stability.

TEST RESULTS

The team did some tests on the frame to see how sturdy it would be when forces were applied. The force the students simulated was as if a child was riding it, Figure 5. The team then decided to put up to 400 lbf on the frame to see how well it would withstand that much force, Figure 6. The team ended up with a factor of safety of 5.04 and a displacement of 0.00017 in.



Figure 5: Force Simulation

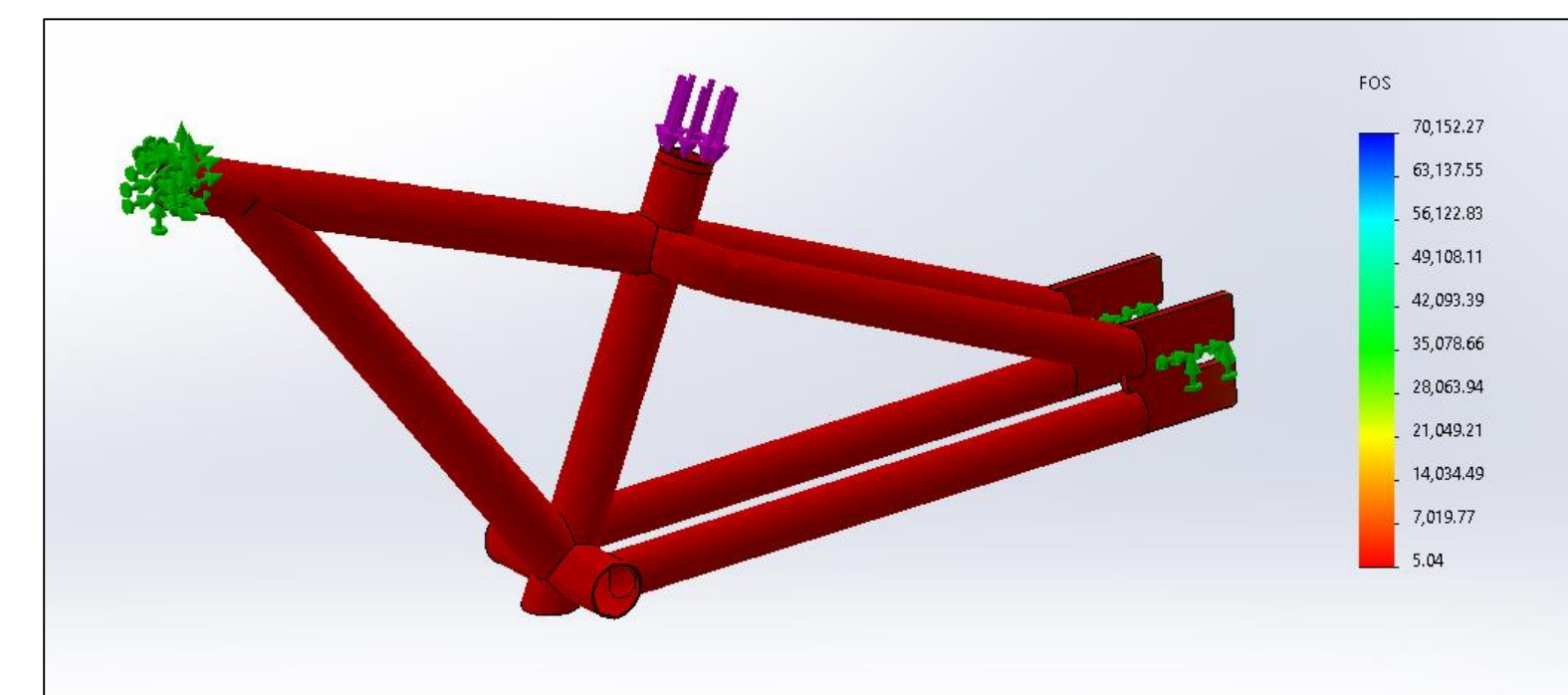

Figure 6: Factor of Safety

FINAL DESIGN

After a lot of research and rework the team came up with a design that fit all of the requirements set by the sponsor. Shown in Figure 7 is the final CAD model of the bike. The team re-designed the modularity aspect for the front of the bike from 6 inches to 3 inches which still accommodates for the wheel. The other points of modularity are the same. Figure 8 shows the unpainted bike assembly.



Figure 7: Completed CAD Model



Figure 8: Prototype Before Paint

CONCLUSION

The team has assembled a rideable modular prototype for the sponsor. This was shown by one of the members being able to ride the prototype without difficulty. The bike can be easily adjusted to fit the standard sizes of a child from ages 3 – 9. The team used the different design phases that were laid out according to the course to complete the project in a timely manner, create a working design and have a presentable prototype to show for under a certain amount that was defined by the sponsor. Figure 9 shows the fully rideable bike ready for action.



Figure 9: Final Assembly

LESSONS LEARNED

Throughout the project this team learned:

- Effective communication
- Time management
- How roles change throughout the process
- How to research in detail & how patents effect the design process
- Designs can always change

ACKNOWLEDGEMENTS

Atulya Dhungana, Project Sponsor
 Dr. Timothy Jenkins, Associate Professor, Design Engineering Technology
 Timerson Downing, Project Manager, Innovation One
 Joe Thompson, Lab Technician, Trine University